

## Application

**Rigid wall:** The walls must have a minimum thickness of 100mm (Or as indicated in the table below) and comprise of Concrete, aerated Concrete, Block or Masonry with a minimum density of 650 Kg/m<sup>3</sup>. Wall System should be classified to EN13501-2 and FP170 Intucollar applied to both sides of the wall.

- All surfaces must be clean and sound, free from dirt, grease and other contamination.
- Check substrate, pipe material and dimensions are suitable for FP170 Intucollar application. By referencing the product performance tables.
- Apply a smoke seal around the pipe to substrate abutment; must be either FS702 Intumastic or FS709 HP Intumescent Sealant
- Position the FP170 Intucollar around the pipe and then slide the retaining clip into position and fold back, or secure latch depending on collar type.
- Abut the FP170 Intucollar to the substrate and secure, through all the fixing locations provided.
- Use non-combustible fixings suitable for the substrate.

## Important Information:

- Do not use around CPVC pipes; for this specific application, please use FS719 HP Blue for CPVC.
- Safety data sheet and Technical data sheet must be read and understood before use.
- Minimum fixing length of 40mm suited to the substrate
- Maximum core drilled hole may be up to 10mm larger than the pipe diameter. FS702 sealant can then be applied as a smoke seal behind the collar.

The following test configuration allows for the following:

		Tested			
		U/U	C/U	U/C	C/C
Covered	U/U	Y	N	N	N
	C/U	Y	Y	N	N
	U/C	Y	Y	Y	N
	C/C	Y	Y	Y	Y

Y = acceptable, N = not acceptable

Where U is uncapped and C is capped and the first letter indicates the fire side

For other substrate types contact the Technical team

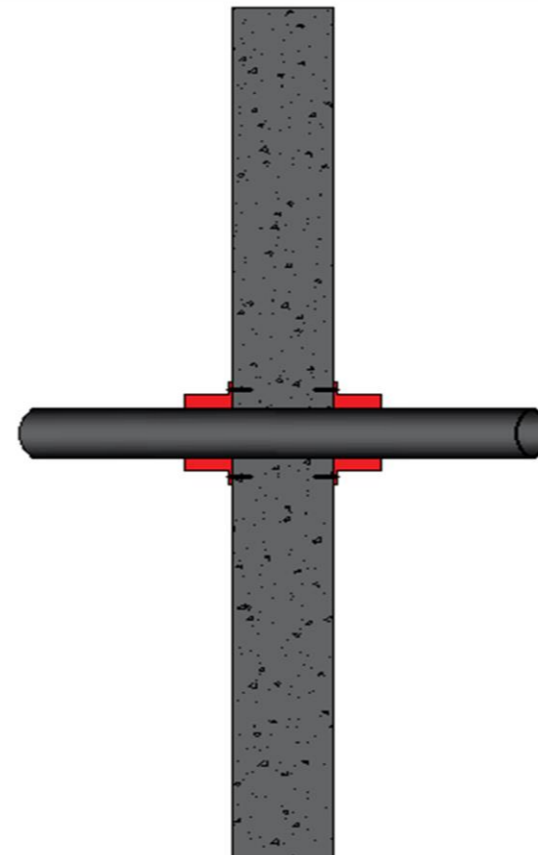

Service	Diameter pipe (mm)	Pipe wall thickness (mm)	Collar Inlay (mm)	Rigid wall ≥ 100 mm	Rigid wall ≥ 130 mm	Classification
PVC-U **	∅ 55 **	2,0 **	45 x 16	✓	✓	EI 60 U/U
PVC-U	∅ 110	1,8 – 4,2	30 x 10	✓	✓	EI 240 U/U
PVC-U	∅ 125	2,5	45 x 16	✓	✓	EI 240 U/U
PVC-U	∅ 125	4 - 9,5	45 x 16	✓	✓	E 120 I 90 U/U
PVC-U	∅ 125	2,5 - 9,5	45 x 16		✓	EI 120 U/U
PVC-U	∅ 140	2,5	45 x 16	✓	✓	EI 240 U/U
PVC-U	∅ 140	4 - 9,5	45 x 16	✓	✓	E 120 I 90 U/U
PVC-U	∅ 140	2,5 - 9,5	45 x 16		✓	EI 120 U/U
PVC-U	∅ 160	2,5	45 x 16	✓	✓	EI 240 U/U
PVC-U	∅ 160	4 - 9,5	45 x 16	✓	✓	E 120 I 90 U/U
PVC-U	∅ 160	2,5 - 9,5	45 x 16		✓	EI 120 U/U
PVC-U	∅ 200	10,6	130 x 24	✓	✓	EI 240 U/U
PVC-U	∅ 200	10,6	60 x 26	✓	✓	EI 90 U/U
PVC-U	∅ 225	10,6	130 x 24	✓	✓	EI 240 U/U
PVC-U	∅ 225	10,6	60 x 26	✓	✓	EI 90 U/U
PVC-U	∅ 250	10,6	130 x 24	✓	✓	EI 240 U/U
PVC-U	∅ 250	10,6	60 x 26	✓	✓	EI 90 U/U
PVC-U	∅ 315	12,1	130 x 32	✓	✓	EI 120 U/U

\*Consult the ETA for detailed information

\*\* 0-45° pipe angle and 160 mm diameter pipe collar over an oval opening 60 x 83 mm with gaps sealed using Nullifire FS702 sealant

## Combustible pipe rigid wall (≥ 100 mm)

**FP170-RW100-SI-01-00026**

Tested according to EN 1366-3, classified to EN 13501-2

ETA -21/0183

Date of issue: 2021-01-15

Suitable for rigid walls, the performance of the fire stopping will always be limited to the performance of the surrounding substrates.



Minimum Distances

To substrate 0mm  
Collar to collar 50mm (WF432241)

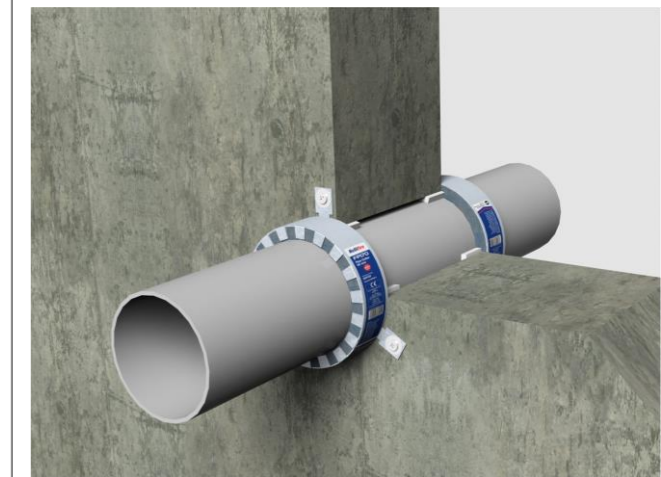

*The published fire ratings stated in this document have been achieved by strictly following the instructions set out in the ETA. The use of alternative components or any deviation from these instructions will invalidate the solutions provided in this document. CPG UK Ltd accept no responsibility for the use of Nullifire products or other CPG products in any applications or purposes not authorised or recommended by CPG. Further expert advice should always be sought where such applications are to be considered. This information is provided in good faith and is believed to be correct as of the date of publication based upon tested and certified solutions. The reader must always ensure that they are following the latest published versions of any drawings and instructions. CPG UK Ltd. assumes no liability, expressed or implied, as to the design, architecture, engineering, or workmanship of any project.*

V1 10.08.2023

Service	Diameter pipe (mm)	Pipe wall thickness (mm)	Collar Inlay (mm)	Flexible and Rigid wall ≥ 100 mm	Flexible and Rigid wall ≥ 130 mm	Classification
<b>PE pipe according to EN 1519-1, EN 12201-2 and EN 1266-1, ABS pipe according to EN 1455-1 and SAN+PVC pipe according to EN 1565-1</b>						
PE / ABS / SAN+PVC	∅ 40	3,0 - 4,6	30 x 6	✓	✓	EI 120 U/U
PE / ABS / SAN+PVC	∅ 50	3,0 - 4,6	30 x 6	✓	✓	EI 120 U/U
PE / ABS / SAN+PVC	∅ 75	4,5 - 6,8	30 x 6		✓	E 120 I 90 U/U
PE / ABS / SAN+PVC	∅ 75	4,5	30 x 6	✓	✓	E 120 I 90 U/U
PE / ABS / SAN+PVC	∅ 75	4,5 - 6,8	30 x 6	✓	✓	EI 90 U/U
PE / ABS / SAN+PVC	∅ 90	2,7	30 x 10		✓	EI 120 U/U
PE / ABS / SAN+PVC	∅ 90	2,7 - 6,6	30 x 10	✓	✓	E 120 I 90 U/U
PE / ABS / SAN+PVC	∅ 90	10	30 x 10		✓	EI 90 U/U
PE / ABS / SAN+PVC	∅ 110	2,7	30 x 10		✓	EI 120 U/U
PE / ABS / SAN+PVC	∅ 110	2,7 - 6,6	30 x 10	✓	✓	E 120 I 90 U/U
PE / ABS / SAN+PVC	∅ 110	10	30 x 10		✓	EI 90 U/U
PE / ABS / SAN+PVC	∅ 125	4,8	30 x 10	✓	✓	EI 90 U/U
PE / ABS / SAN+PVC	∅ 125	4,9 - 14,6	45 x 16	✓	✓	EI 60 U/U
PE / ABS / SAN+PVC	∅ 125	6,2	45 x 16	✓	✓	EI 240 U/U
PE / ABS / SAN+PVC	∅ 125	9,5	45 x 16		✓	EI 120 U/U
PE / ABS / SAN+PVC	∅ 140	14,6	45 x 16	✓	✓	EI 60 U/U
PE / ABS / SAN+PVC	∅ 140	6,2	45 x 16	✓	✓	EI 240 U/U
PE / ABS / SAN+PVC	∅ 140	9,5	45 x 16		✓	EI 120 U/U
PE / ABS / SAN+PVC	∅ 160	14,6	45 x 16	✓	✓	EI 60 U/U
PE / ABS / SAN+PVC	∅ 160	6,2	45 x 16	✓	✓	EI 240 U/U
PE / ABS / SAN+PVC	∅ 160	9,5	45 x 16		✓	EI 120 U/U

Consult the ETA for detailed information

\*\* 0-45° pipe angle and 160 mm diameter pipe collar over an oval opening 60 x 83 mm with gaps sealed using Nullifire FS702 sealant

**Combustible pipe**  
rigid wall (≥ 100 mm)

**FP170-RW100-SI-01-00026**



Service	Diameter pipe (mm)	Pipe wall thickness (mm)	Collar Inlay (mm)	Flexible and Rigid wall ≥ 100 mm	Flexible and Rigid wall ≥ 130 mm	Classification
<b>PP pipe according to EN ISO 15494</b>						
PP	∅ 40	2	30 x 6	✓	✓	EI 120 U/U
PP	∅ 40	2,1 - 4,3	30 x 6	✓	✓	E 120 I 60 U/U
PP	∅ 50	2	30 x 6	✓	✓	EI 120 U/U
PP	∅ 50	2,1 - 4,3	30 x 6	✓	✓	E 120 I 60 U/U
PP	∅ 75	2	30 x 6	✓	✓	EI 120 U/U
PP	∅ 75	2,1 - 4,3	30 x 6	✓	✓	E 120 I 60 U/U
PP	∅ 80	2	30 x 6	✓	✓	EI 120 U/U
PP	∅ 80	2,1 - 4,3	30 x 6	✓	✓	E 120 I 60 U/U
PP	∅ 90	2,7	30 x 10	✓	✓	EI 120 U/U
PP	∅ 110	2,7	30 x 10	✓	✓	EI 120 U/U
PP	∅ 140	3,5	45 x 16	✓	✓	E 120 I 45 U/U
PP	∅ 140	4,0	45 x 16		✓	EI 120 U/U
PP	∅ 160	4,0	45 x 16		✓	EI 120 U/U
PP	∅ 140	4,0 - 14,6	45 x 16		✓	E 120 I 45 U/U
PP	∅ 160	4,0 - 14,6	45 x 16		✓	E 120 I 45 U/U

Service	Diameter pipe (mm)	Pipe wall thickness (mm)	Collar Inlay (mm)	Flexible and Rigid wall ≥ 100 mm	Flexible and Rigid wall ≥ 130 mm	Classification
<b>Misc</b>						
BevEx Drinks Python	∅ 80	-	30 x 6	✓	✓	EI 240 U/U
Steel pipe with 25mm CS K Flex or Armaflex Insulation	∅ 219,1	6,4 – 14,2	130 x 32	✓	✓	EI 240 U/U
Steel pipe with 13mm CS K Flex or Armaflex Insulation	∅ 47,6	1,5 – 14,2	30 x 6	✓	✓	EI 240 C/C
Steel pipe with 19mm CS K Flex or Armaflex Insulation	∅ 114,3	2,0 – 14,2	45 x 16	✓	✓	EI 240 C/C